

# Position Transmitters and Limit Switches



# Position Transmitters (XFlo)

## Design: Features that spell Reliability

Today's modern process control systems need Position Transmitters (XFlo) position transmitter and switches that deliver the level of accurate position sensing need.

The infinite resolution potentiometer in Position Transmitters (XFlo) senses the exact position of a valve coupled with a two-wire transmitter and sends a continuous 4-20mA signal to a remote indicating device.

The Position Transmitters (XFlo) output can be comfortably adjusted from 5 to 90 degree input rotation with multi-turn zero and span adjustments. The reversing of action is accomplished easily by a switch located on the circuit board. Position Transmitters (XFlo) can be ordered with the analog 4-20mA position transmitter either alone or with two independently adjustable (SPDT) limit switches. Also available are models with two (LS2) or four (LS4) independently adjustable limit switches only.

Another important feature of the Position Transmitters (XFlo) rugged cast aluminum housing is that it is explosion proof, weather proof and dust proof. Humidity protection is provided to the transmitter circuit with conformal coating. The transmitter circuit incorporates solid state integrated circuitry with few components for reliable performance.

For standard Mascot linear and rotary actuators, mounting hardware is available. Another utility for Position

### FEATURES AND ADVANTAGES:

**High accuracy** Accurate transmission of linear signal within  $\pm 1.0$  percent across the whole range.  
**Two-wire design** The unique two-wire design reduces field wiring costs.

**Easy field adjustments** Convenience of easy field adjustments cover non interacting multi-turn zero and span settings, reverse polarity action switch, clockwise or counter clockwise operation.

**Rugged cast aluminum housing** Cast aluminum housing that it is explosion proof, weather proof and dust proof  
**Shock and vibration resistant** Highly resistant to shocks and vibrations and withstands acceleration forces to 483 ft/sec<sup>2</sup>.

**Independent operation** There is an independent operation between limit switches and transmitter.

**Multiple usages** Installation of multiple usage on linear and rotary actuators, louvers, dampers and other devices.

**Stable operation** Highly stable while operating in ambient temperature changes and fluctuations of power supply. Adjustable span from 5 degree to 90 degree rotation of shaft.

**Reverse polarity protected** Trouble free installation because of reverse polarity protection. Meets with IS 2148-1981 for group II A, IIB & II C.

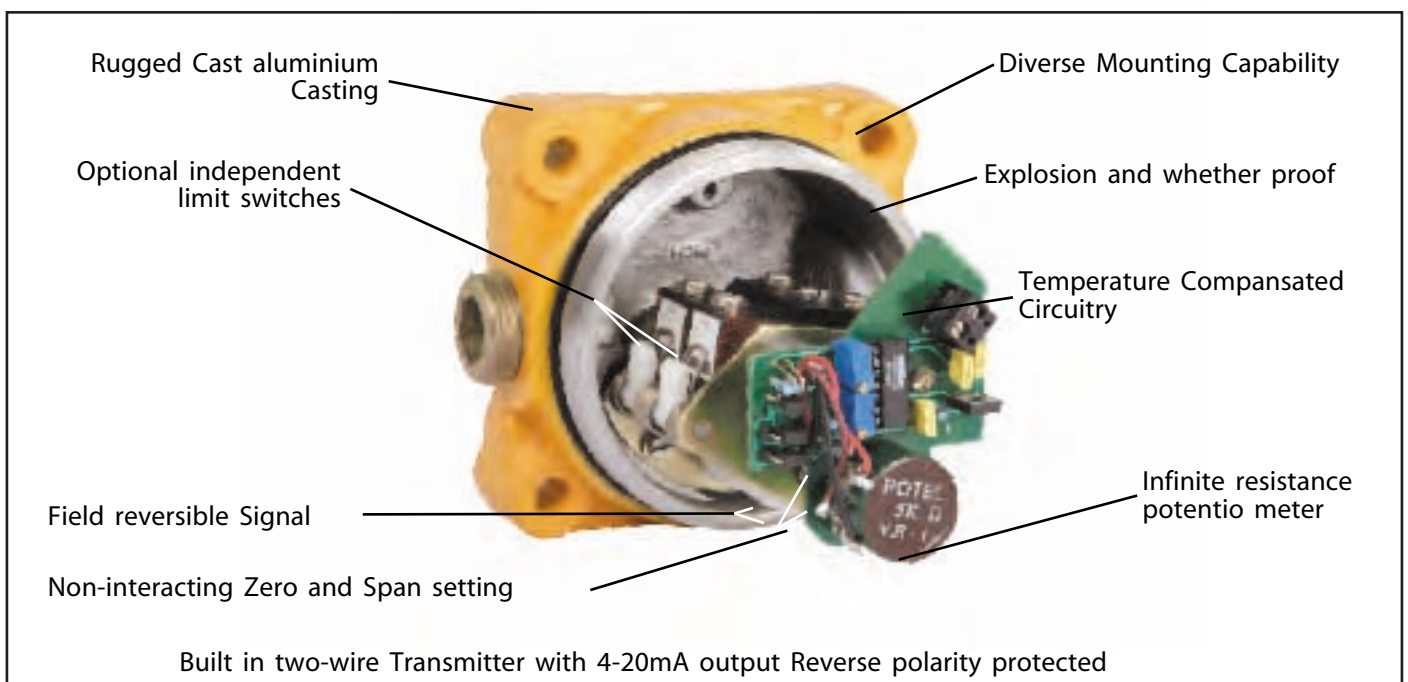

# Position Transmitters (XFlo)



Our reputation

## Specification

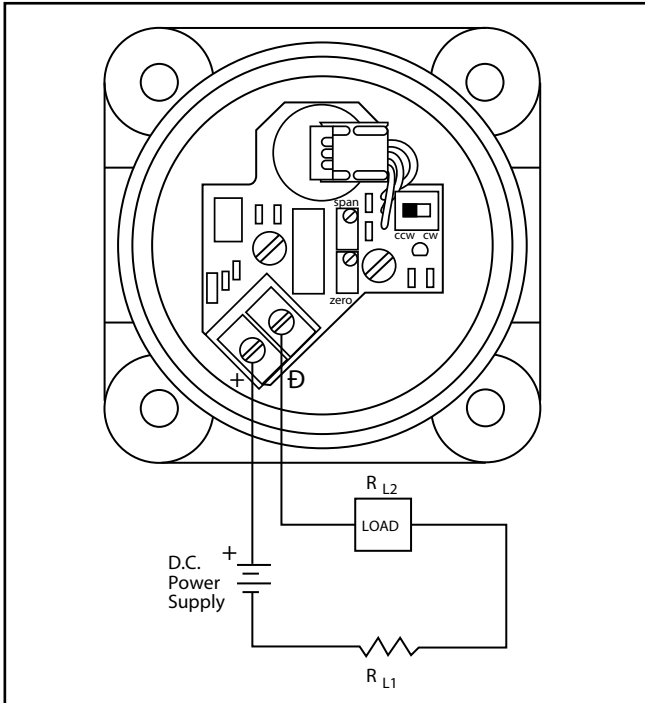

Table I: Specifications

### Analog Output

Power supply range	12.5 to 40 VDC (24V DC typical)
Maximum load resistance (see figure 3)	Maximum Resistance (ohms) = $\frac{\text{Supply Voltage} - 12.5}{.02}$
Current signal output	4-20 mA
Span	Adjustable from 5 ° to 100 ° of angular rotation
Null	4 mA position may be set at any angular position
Linearity	±1.0% full scale*
Repeatability	±0.25% full scale
Hysteresis	±1.0% full scale
Operating temperature range	-40° to 185 ° F (-40° to 85 ° C)
Ambient temperature range	For a 100 ° F (38° C) change in ambient temperature, maximum zero shift is ±0.4% full scale, maximum span shift is ±0.7% full scale
Power Supply	Output signal changes less than 0.05% when supply voltage is varied between 12.5 and 40 volts dc

### Limit Switches

(SPDT) UL/CSA Rating (L23)	20 amps, 125, 250, 480 VAC, ind. and res. 1 Hp, 125 VAC; 2 Hp, 250 VAC, .5 amp, 125 VDC; .25 amp, 250 VDC res.
-------------------------------	--

### Mechanical

Input motion	±105° from the center; spring loaded to return to the center
--------------	--

\* Linearity is ±1.0% for 90 ° rotary shaft input. When mounted to linear travel valves, linearity is dependent on linkage design and stroke length. Typical linearity is ±1.5% full scale on G Series valves.

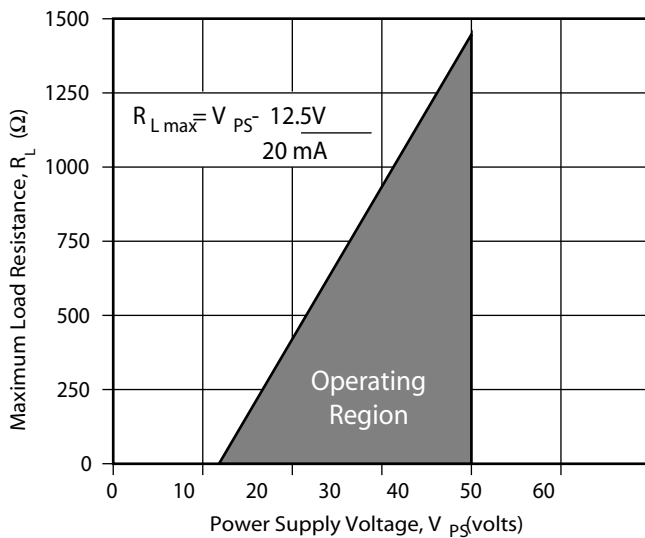

Figure 3: Power Supply Requirements

Table II: Model Configuration

Description	Model Number	Housing Size
Analog transmitter only	PT	Short
Analog transmitter with two SPDT switches	PTLS2	Long
Two SPDT switches only	LS2	Short
Four SPDT switches only	LS4	Long
Two SPDT switches with terminal switch	P2TS	Long
Two SPDT switches with terminal strip	P2TSt	Long

# Position Transmitters (XFlo)

## Dimension

### Mounting Dimensions (inches / mm)

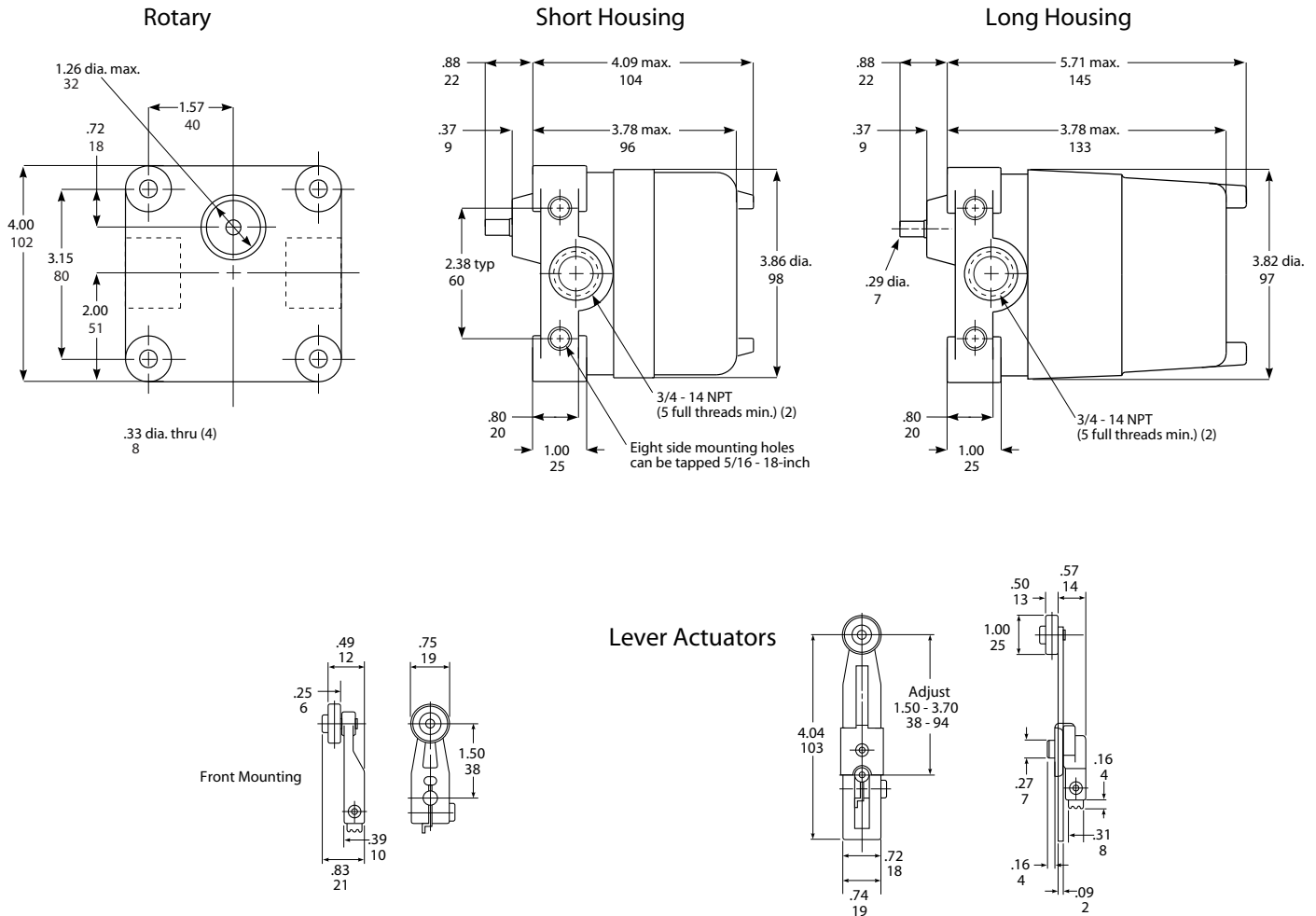

Best efforts have been made to keep the information accurate. The literature is for information and should not be considered as certified or as a guarantee of results by relying on it. No part of this literature is to be construed as a warranty or guarantee, expressed or implied, regarding any matter with respect to the product. Continual up-gradation in product design being imperative, the dimensions, specifications, design and information are subject to change without notice. Please consult our representative or factory for details. Instructions for installation, operation, maintenance or trouble shooting of Position Transmitters (XFlo) are contained in the Installation, Operation and Maintenance instructions section. These instructions should be read and understood thoroughly and followed in exactness by all personnel responsible for these operations. Installation, Operation, Maintenance instructions are provided by us through our representatives on field or at our factory and office.